

Bariatric Ceiling Lift



Lifts up to 1000 lbs.

- Single motor
- Cycloidal drive train mechanism
- Extremely efficient, leads to longer battery life and more lifts
- Automatic sleep function provides battery conservation
- Electronic braking system – provides the ultimate safety feature because the brake is always applied except when the motor is lifting/lowering a patient
- Smart battery charger — cleans batteries while charging to prolong life of batteries beyond all other standard chargers
- Maintenance-free internal drive train system (greaseless)
- Two 7.2 amp, 12 volt batteries — even if battery is drained, lift will always go down
- No audible alarm for emergency stop — won't scare patients

Item Number:

700100 – Bariatric Ceiling Lift - 1000 lbs. capacity

Features:

- *Auto-leveling hanger bar system*
- *Bright, easy-to-read digital display time meter*
- *Manual traversing*
- *Return to charge*
- *Visual low battery indicator*
- *Emergency lowering system*
- *Anti-slack strap retraction*
- *Re-coiling anti-twist strap*
- *Built-in safety stops*
- *Electronic hand control*
- *Scale option*
- *Automatic battery conservation*
- *Soft start/stop for comfort*
- *Smart battery charger*
- *Heavy duty batteries for more lifts*
- *2 year warranty (excludes batteries)*

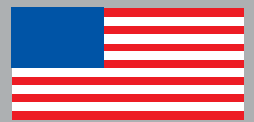

MADE IN THE USA



Medcare Bariatric Ceiling Lift 1000

Model #700100 – lifts up to 1000 lbs.

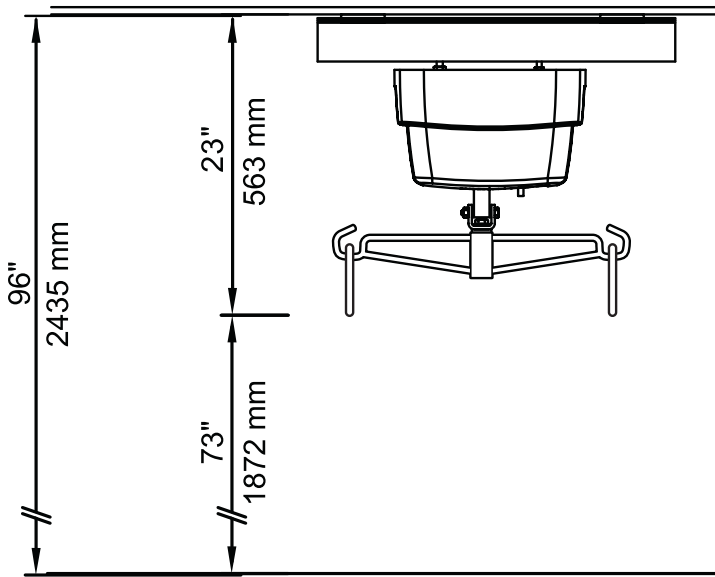

Technical Specifications

Lift Motor:	24 VDC (All models)	Hand Control:	Sealed Electric Membrane Switch
Return to charge Motor:	24 VDC	Lifting Height:	Up to 92"
Charger Input:	110 VAC, 1.0 Amps	Hoist Weight:	48 lbs.
Charger Output:	24 VDC, 1.5 Amps	Maximum Load:	1000 lbs.
Batteries:	24 VDC (2 x 12 VDC), 7.2 AH	Warranty:	Two Years (excludes batteries)
Lift Case:	Flame Retardant ABS		

PRODUCT HIGHLIGHTS

- Automatic sleep function provides battery conservation
- Auto-leveling hanger bar system
- Digital display running time meter
- Hour meter indicates actual motor run-time to assist in performing preventative maintenance services & scheduling
- Visual battery life & battery replacement indicators
- 92" lifting range allows lifting from the floor and over high thresholds
- The slack strap sensor ensures the lift strap will not continue to unwind if weight distribution is not even and it also ensures that the strap will not continue to wind if weight is not applied
- Manual lowering in the absence of power
- 4-point, non-rigid hanger bar design allows sling to conform to patient for added comfort



Med
HANDLE WITH CARE.

Hanger Bar Stopper Option

The Medcare Hanger Bar Stopper prevents sling loops from sliding off of the hanger bar hooks.



Item Number:
400611



Medcare Products

151 East Cliff Road
Burnsville, MN 55337
Toll-free: 800-695-4479
Fax: 952-894-7153
www.MedcareLifts.com

© 2011 Medcare Products Inc.
Specifications are subject to change without notice. All products referred herein are registered trademarks or trademarks of their respective holders.